

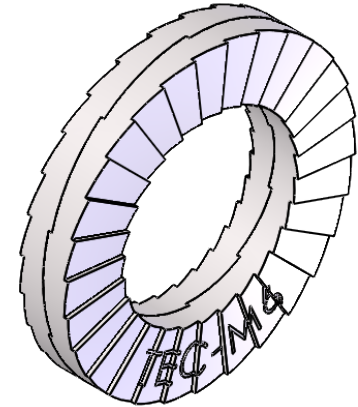

REVISIONS			
REV.	DESCRIPTION	DATE	ECN
A	INITIAL RELEASE	2/27/17	2555
B	HEAT TREAT WAS 480 - 540 HV	3/29/17	2615
C	MATERIAL UPDATE	7/12/2018	3056

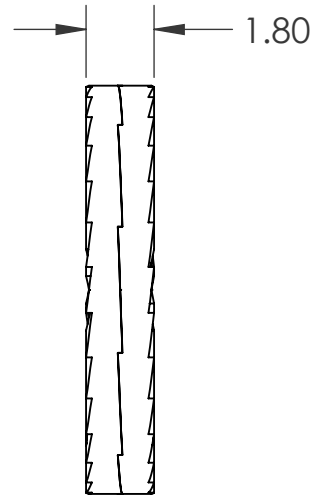
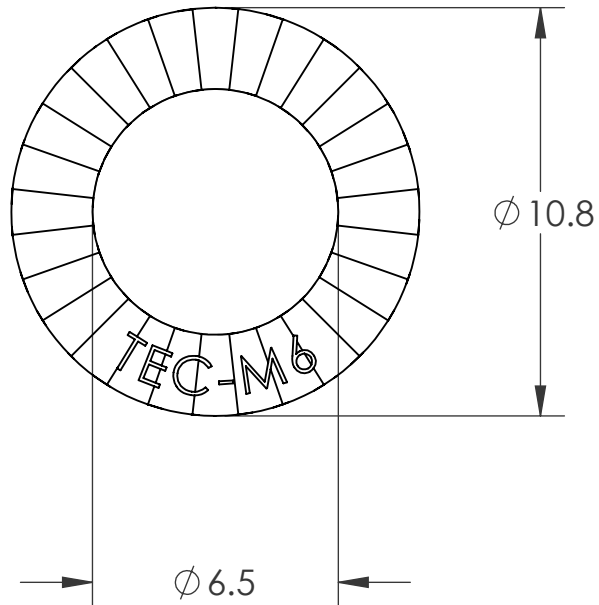

**PROPRIETARY AND CONFIDENTIAL**  
 THIS DRAWING, AND THE INFORMATION CONTAINED HEREIN, ARE THE PROPERTY OF SHEREX AND ARE NOT TO BE USED IN ANY MANNER DETRIMENT TO THE INTEREST OF THE COMPANY.  
 SHEREX FASTENING SOLUTIONS RESERVES THE RIGHT TO REVISE PART/DRAWING WITHOUT NOTICE.

DRAWING NO.:  
**TEC-M6**

UNLESS OTHERWISE SPECIFIED:		NAME	DATE		
DIMENSIONS ARE IN MILLIMETERS TOLERANCES: ANGULAR: MACH ±1 BEND ±1 I.D. TOLERANCE: ±0.1 O.D. TOLERANCE: ±0.2 THICKNESS TOLERANCE: ±0.25		DRAWN	MTB		2/27/17
INTERPRET GEOMETRIC TOLERANCING PER: ASME Y14.5M-1994		CHECKED		DESCRIPTION: <b>TEC WASHER GLUED PAIR 6MM</b>	
MATERIAL		ENG APPR.	JVK		2/27/17
SCM435 OR 4130 STEEL, HT: THROUGH HARDEN 465 HV MIN		MFG APPR.			
FINISH		Q.A.			
DELTA PROTEKT BASE COAT (KL100) & TOP COAT (VH302GZ)		COMMENTS:		SIZE PART NO.: <b>A</b> <b>TEC-M6</b>	
DO NOT SCALE DRAWING		E-mail: <a href="mailto:info@disc-lock.com">info@disc-lock.com</a> <a href="http://www.disc-lock.com">www.disc-lock.com</a> Phone: 866-474-3739 Fax: 716-875-0358		REV <b>C</b>	
		SCALE: 5:1 WEIGHT:		SHEET 1 OF 1	